



User Manual

AS1-3KS-5.1 AS1-3KS-10.2

AS1-3KS-15.3 AS1-3KS-20.4

Content

CONTENT	- 1 -
CHAPTER 1 SAFETY PRECAUTIONS	- 4 -
1.1 SAFETY TIPS	- 4 -
1.2 SYMBOLS INSTRUCTIONS	- 7 -
1.3 EMERGENCY SITUATION	- 8 -
CHAPTER 2 PRODUCT INTRODUCTION	- 12 -
2.1 SCOPE OF APPLICATION	- 12 -
2.2 SYSTEM SCHEMATIC	- 14 -
2.3 PRODUCT MODEL DESCRIPTION	- 14 -
2.3 DATASHEET	- 15 -
CHAPTER 3 INSTALLATION INSTRUCTIONS	- 19 -
3.1 PACKING LIST OF AS1	- 19 -
3.2 DETERMINE THE INSTALLATION METHOD AND LOCATION	- 20 -
3.3 INSTALLATION PROCEDURE FOR AS1	- 23 -
3.4 INSTALLATION PROCEDURE FOR B1	- 26 -

CHAPTER 4 ELECTRICAL CONNECTIONS	- 32 -
4.1 ELECTRICAL INTERFACE DESCRIPTION	- 32 -
4.2 SYSTEM WIRING SCHEMATIC	- 34 -
4.3 AS1 WIRING	- 35 -
4.4 B1 WIRING	- 38 -
4.5 COMMUNICATION INTERFACE DESCRIPTION	- 44 -
4.7 CT INSTALLATION	- 47 -
CHAPTER 5 DEBUGGING INSTRUCTIONS	- 59 -
5.1 HUMAN-COMPUTER INTERFACE INTRODUCTION	- 59 -
5.4 SYSTEM COMMISSIONING	- 61 -
CHAPTER 6 FAULT CODES AND COMMON TROUBLESHOOTING	- 64 -
CHAPTER 7 INVERTER & BATTERY MAINTENANCE	- 69 -
7.1 TRANSPORTATION	- 69 -
7.2 STORAGE	- 69 -
7.3 CLEANLINESS	- 70 -
CHAPTER 8 CONTACT US	- 76 -

WARRANTY CARD - 78 -

Chapter 1 Safety Precautions

This user manual describes the instructions and procedures for the installation of the AS1 AC Retrofit Battery System. Please read the user manual before operating it.

Keep this user manual properly and operate strictly according to all safety tips and operation instructions in this manual.

1.1 Safety Tips



- Electric shock and high voltage.
- Do not expose the inverter to temperatures in excess of 45°C.
- Do not subject the inverter to any strong force.
- Do not touch uninsulated cable termination.
- Do not soak the inverter in water or expose it to moisture environment.
- Do not touch the case of the inverter when it is wet in case of electric shock.
- Do not dispose of batteries in fire. The batteries may explode!
- Do not place the inverter near a heat source, such as direct sunlight, a fireplace.

- Keep inflammable and explosive dangerous items or flames away from the inverter.
- Do not charge or discharge damaged inverter.
- Before performing any work on the inverter or battery pack, please disconnect the inverter from all voltage sources as described in this document.

**Warning**

- Installation, repair, recycling, and disposal of AS1 must be performed by qualified personnel in accordance with national and local standards and regulations.
- To ensure property and personal safety, the battery modules and inverter shall be well grounded.
- Risks of chemical burn electrolyte or toxic gases.
- Do not place heavy objects on the top of the system.
- Do not connect any un-dedicated battery pack to the AS1 /B1.
- If the moisture penetrates the system (e.g. due to casing damage), please do not install or operate the system.
- Do not use wet hands to touch the system.
- Any behavior to change the functionality of the product without permission will cause fatal injury to the operator, third parties, and equipment. SAJ is

not responsible for these losses and warranty claims.







 **Caution**



- Do not modify or tamper with AS1 and other components of the system.
- Risk of injury by hoisting or falling system
- Inverters and batteries are heavy and personal injury can be caused if the inverter or battery is improperly lifted or dropped during transport or improper operation when attached or removed from walls. Lifting and moved the products shall be conducted by more than 1 person.

 **Notice**

- This device contains a built-in lithium battery and a dedicated extended battery. Do not extend the battery pack with other brand battery at the battery port.
- AS1 outputs AC power directly to the utility grid and the backup loads. Do not reverse the output of the two AC terminals of the inverter.

1.2 Symbols instructions

Symbol	Description
	<p>Dangerous electrical voltage</p> <p>The device is directly connected to public grid, thus all work to the battery shall only be carried out by qualified personnel.</p>
	<p>No open flames</p> <p>Do not place or install near flammable or explosive substances.</p>
	<p>Corrosive substance</p> <p>Keep the inverter away from corrosive substance.</p>
	<p>Danger of hot surface</p> <p>The components inside the device will release a lot of heat during operation. Do not touch metal plate housing of the device.</p>
	<p>Attention</p> <p>Install the product out of reach of children</p>
	<p>An error occurred</p> <p>Read the usage manual to troubleshoot problems</p>

	<p>This device SHALL NOT be disposed of in residential waste</p> <p>Please go to Chapter 8 “Recycling and Disposal” for proper treatment.</p>
	<p>CE Mark</p> <p>The device is in compliance with Low Voltage Directive and Electromagnetic Compatibility.</p>
	<p>Recyclable</p>

1.3 Emergency situation

Despite of its careful and professional protection design against any hazard results, damage of the battery may still occur. If a small amount of battery electrolyte is released due to a serious damage of the outer casing; or if the battery explodes due to not being treated timely after a fire breaks out nearby, and leaks out poisonous gases such as carbon monoxide, carbon dioxide and etc., the following actions are recommended:

- 1) Eye contact: Rinse eyes with a large amount of running water and seek medical advice.
- 2) Contact with skin: Wash the contacted area with soap

thoroughly and seek medical advice.

3) Inhalation: If you feel discomfort, dizziness or vomiting, seek medical advice immediately.

4) Use a FM-200 or Carbon Dioxide (CO₂) fire extinguishers to extinguish the fire if there is a fire in the area where the battery pack is installed. Wear a gas mask and avoid inhaling toxic gases and harmful substances produced by the fire.

5) Use an ABC fire extinguisher, if the fire is not caused by battery and not spread to it yet.

 **Warning**

- If a fire has just occurred, try to disconnect the battery circuit breaker and cut off the power supply first, but only if you can do so without endangering yourself.
- If the battery is on fire, do not attempt to extinguish the fire but evacuate the crowd immediately.

Potential danger of damaged battery:

Chemical Hazard: Despite of its careful and professional protection design against any hazard results, rupture of battery shall may still

occur due to mechanical damage, internal pressure and etc., and may result in a leakage of battery electrolyte. The electrolyte is corrosive and flammable. When there is fire, the toxic gases produced will cause skin and eyes irritation, and discomfort after inhalation. Therefore:

- 1) Do not open damaged batteries;
- 2) Do not damage the battery again (shock, fall, trample, etc.);
- 3) Keep damaged batteries away from water (except to prevent an energy storage system from catching fire);
- 4) Do not expose the damaged battery to the sun to prevent internal heating of the battery.

Electrical hazard: The reason of fire and explosion accidents in lithium batteries is battery explosion. Here are the main factors of battery explosion:

- 1) Short circuit of battery. Short circuit will generate high heat inside battery, resulting in partial electrolyte gasification, which will stretch the battery shell. The temperature reaching ignition point of internal material will lead to explosive combustion.
- 2) Overcharge of battery. Overcharge of battery may precipitate

lithium metal. If the shell is broken, it will come into direct contact with the air, resulting in combustion. The electrolyte will be ignited at the same time, resulting in strong flame, rapid expansion of gas and explosion.

Chapter 2 Product Introduction

2.1 Scope of application

AS1 series is designed for energy storage retrofits and is an innovative type of AC coupled energy storage system. The built-in lithium battery inside AS1 can be expanded in capacity according to user demands, and the modular design of the slave device makes it easy to install wiring. The AS1 series includes AS1-3KS-5.1, AS1-3KS-10.2, AS1-3KS-15.3 and AS1-3KS-20.4 models.

In daytime, electricity generated by photovoltaic system will be supplied to loads first, the surplus energy will charge battery then the excess electricity will be exported to the grid to improve self-consumption rate.

At valley power price hours, AS1 can be charged by grid power and can be called on at peak power price hours to support household loads. In case of grid fault, AS1 will make sure no outage in the load, achieving UPS function.

The AS1-3KS-5.1 (herein after refers to AS1) can be used independently or combined with a dedicated battery pack (Model: B1-5.1-48, hereinafter refers to the B1) to enlarge the battery capacity. One to three units of B1 can be connected to the AS1 (three units at most).

Model	Capacity	Note
AS1-3KS-5.1	5.1kWh	1* AS1 only
AS1-3KS-10.2	10.2kWh	1* AS1+1* B1
AS1-3KS-15.3	15.3kWh	1* AS1+2* B1
AS1-3KS-20.4	20.4kWh	1* AS1 +3* B1

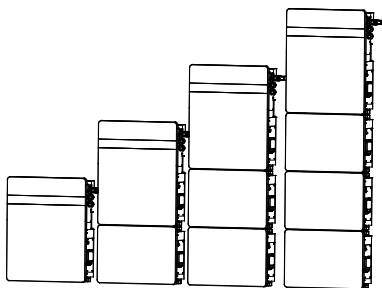

Figure 2.1 Configuration of AS1-3KS-5.1/AS1-3KS-10.2/ AS1-3KS-15.3,/AS1-3KS-20.4

Note: Please do not connect any other brands of battery packs (except for the B1-5.1-48 battery pack) to the battery ports of AS1 series products.

2.2 System Schematic

The schematic of PV system is shown below:

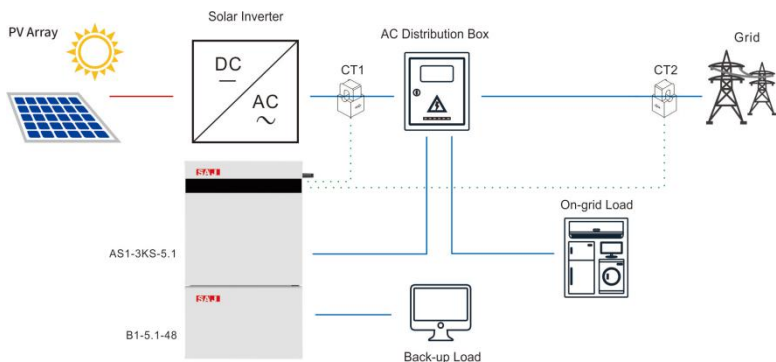

Fig. 2.1 System schematic diagram

2.3 Product Model Description

AS1 – XKS – XX

① ② ③ ④

- ① AS1 represents the product series.
- ② XK indicates the rated power of the product XkW, such as 3K for 3kW.
- ③ S represents single phase; T represents three phase.

④ Indicates the built-in battery capacity, such as 5.1 for 5.1kWh.

2.3 Datasheet

Type	AS1-3KS-5.1	AS1-3KS-10.2	AS1-3KS-15.3	AS1-3KS-20.4
Battery Data				
Battery Type	Lithium ion			
Total Energy Capacity[Wh]	5120	10240	15360	20480
Battery Capacity [Ah]	100	200	300	400
Rated Voltage [V]	51.2			
Voltage Range [V]	42~58.4			
Depth of Discharge[DOD]	≤90%			
Cycle Life	≥6000			
Max.Charge Current [A]	60			
Max.Discharge Current [A]	60			
Scalability	AS1	AS1+B1	AS1+2*B1	AS1+3*B1
Grid Data				

Max. Continuable Output Power [VA]	3000
Max.Output Current [A]@230Vac	13.1
Max.Output Fault Current [A]	28
Inrush Current [A]	50
Max.Output Overcurrent Protection [A]	28
Rated Grid/Backup Voltage/Range [V]	220, 230, 240/180-280
Rated Grid/Backup Frequency/Range [Hz]	50, 60/±5
Power factor [cos φ]	0.8 leading~0.8lagging
Feed-in	L+N+PE

AC Output [Back-up Mode]	
Max. Continuable Output Power [VA]	3000
Output Voltage [V]	220/230/240
Max.Output Current [A]@230Vac	13.1
Output Frequency [Hz]	50/60
Max.Output Power [VA]	3600 ,10sec
General Data	
Communication Mode	Wi-Fi/4G/Ethernet(Optional)
Operating Temperature Range	0°C~50°C (>45°C derating)
Cooling Method	Natural Convection
Ambient Humidity	0-95% Non-condensing
Noise[dBA]	<29
Ingress	IP65

Protection				
Dimensions [H*W*D][mm]	738*650*186	1160*650*186	1580*650*186	2000*650*186
Weight [kg]	64	112	160	208
Standard Warranty [Year]	5			
Applicable Standard	AS 4777.2, VDE 4105, G98, C10/C11, CEI0-21, IEC 62619, IEC 62040			

Chapter 3 Installation Instructions

3.1 Packing List of AS1







			
1* AS1	1* Mounting Bracket	6*Hexagon head wood screw 6* Expansion tube 6* Screw washer	1* 4G Module
			
2* CT	1* Cross recessed hexagon bolts group (M6*12)	6* E6012 tubular insulator terminal	1* User Manual

Table 3.1 Packing List for AS1

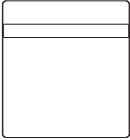
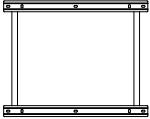
3.2 Determine the Installation Method and Location

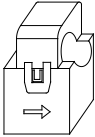
AS1 series product dimension

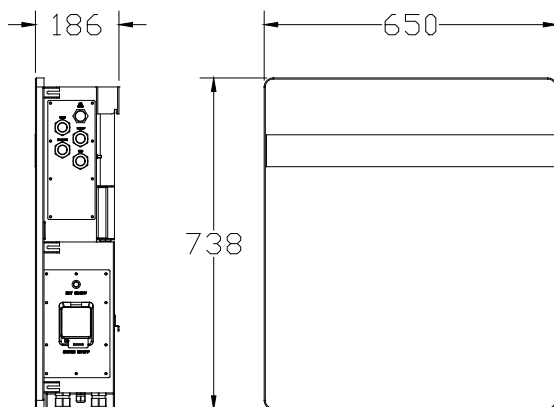

Fig. 3.1 AS1-3KS-5.1 apparent and dimension diagram

AS1-3KS-5.1 is cooled by natural wind convection. It is recommended to install in indoors or sheltered areas to avoid direct sunlight, rain and snow.

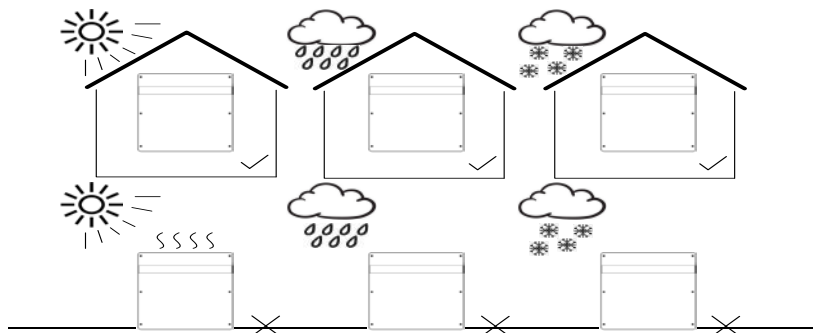

Fig. 3.2 Installation location

Vertical ground mounting method is recommended and it is allowed to be installed by maximum tilting 15° backward. Do not install it horizontally or upside down.

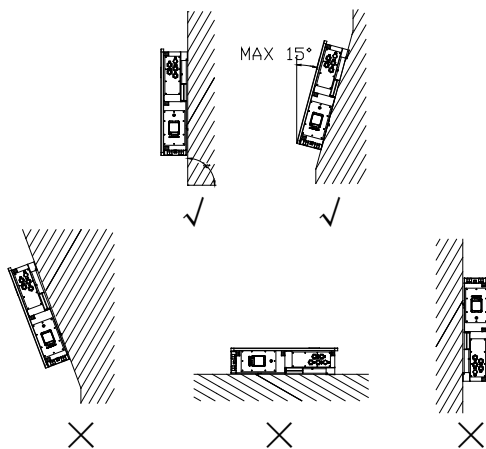

Fig. 3.3 Installation angle

Please ensure the air circulation is good at the installation area for heat dissipation. Bad air ventilation will affect the working performance of internal electronic components and shorten the service life of AS1.

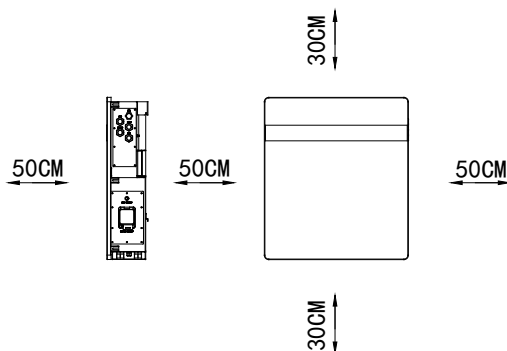

Fig. 3.4 Installation distance

The following sites are not allowed for installation:

- a. within 600mm of any exit;
- b. within 600mm of any vertical side of a window or building ventilation that ventilates a habitable room;
- c. in ceiling spaces
- d. in wall cavities or under stairways;
- e. on roofs, except for were specially deemed suitable
- f. under access walkways

- g. sites where the freezing point is reached, like garages, carports or other places;
- h. sites with humidity and condensation is above 85%;
- i. places with plenty of salt;
- j. flooded areas;
- k. within 600mm of any hot water unit, air conditioning unit or any other appliance associated with the pre-assembled integrated battery energy storage system

3.3 Installation Procedure for AS1

Notice: If any B1 connected to the AS1, please refer to Chapter 3.4 first.

If ONLY installing the AS1 without any B1 connection, please go forward to install the AS1 with instructions in this section below:

Before installation, please make sure that the wall has sufficient strength to fix the screws and bear the weight of AS1.

Step 1: Pre-check the installation distance of the AS1 to other items;

Step 2: Positioning the Mounting bracket of the AS1 to the wall;

Mark the proper positions of mounting bracket and drill holes on those positions (8mm in diameter, 50mm in depth) by using the mounting bracket as a template, and then use a rubber hammer to

drive the screw fixing seat into the holes to fix the bracket.

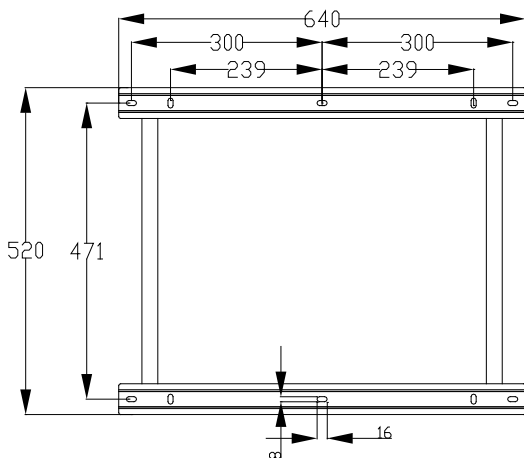

Fig. 3.5 Dimensions of Mounting Bracket for AS1 Unit: mm.

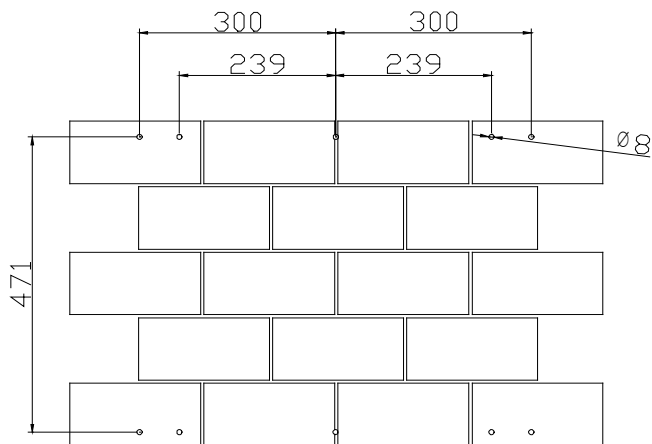

Fig. 3.6 Position of holes on the wall Unit: mm

- Fix the mounting bracket with hex head screw on the installation positions.

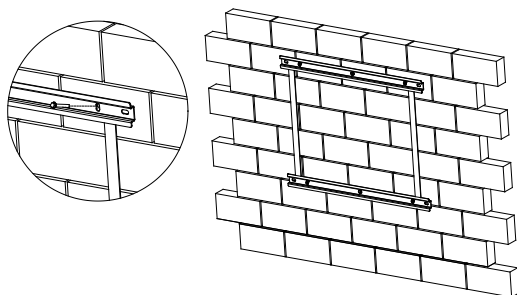

Fig. 3.7 Fixing the mounting bracket

Step 3: Please hang the AS1 to the mounting bracket and make sure the device is snugly fits with the bracket.

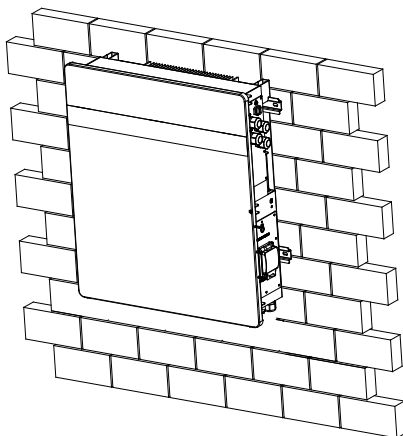

Fig.3.8 Hang the AS1 to the Mounting Bracket

3.4 Installation Procedure for B1

Notice: If any B1 device is connected to the AS1, please install the B1 prior to AS1 installation in case the space is not enough. If no B1 connected to the AS1, please ignore this section.

The installation procedures for the B1 are as following:

Step 1: Pre-check the installation distance of the B1 to other items.

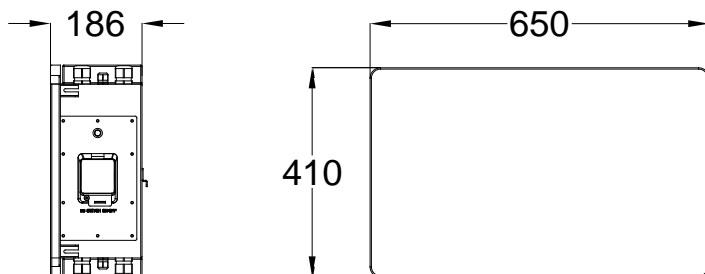

Fig.3.9 B1-5.1-48 dimension (Unit: mm)

Step 2: Mark the proper positions of mounting bracket and drill holes on those positions (8mm in diameter, 50mm in depth) by using the mounting bracket as a template, and then use a rubber hammer to drive the screw fixing seat into the holes to fix the bracket.

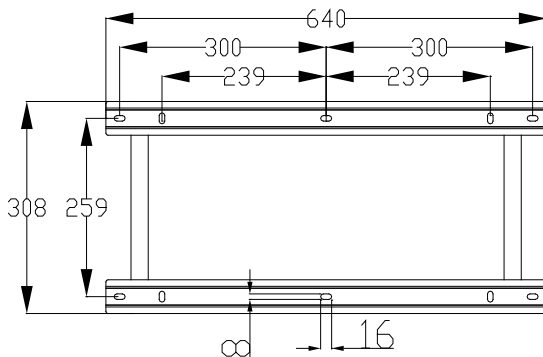

Fig. 3.10 B1-5.1-48 hanging panel dimension

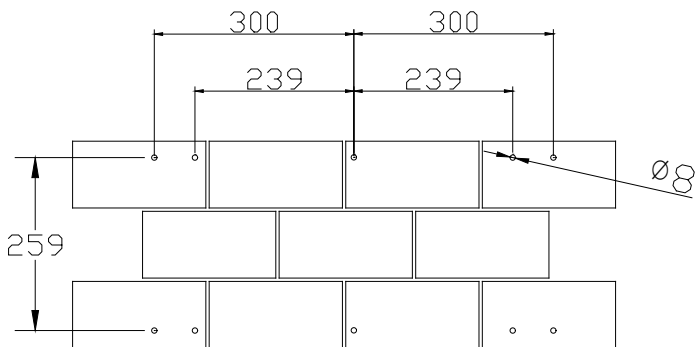

Fig.3.11 B1-5.1-48 Hanging holes position on the wall Unit: mm

Note: The recommended installation distances among the AS1 and the B1 mounting brackets can be found in Fig. 3.12.

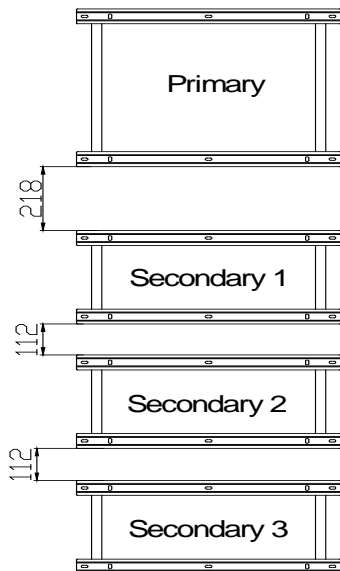

Fig. 3.12 Distances among mounting brackets Unit: mm

Step 3: After the mounting bracket fixed and before hanging the AS1/ B1 on the mounting bracket, please remove the plug from the waterproof nut of the AS1 and B1, then put on the cable gland but not tighten it up yet.

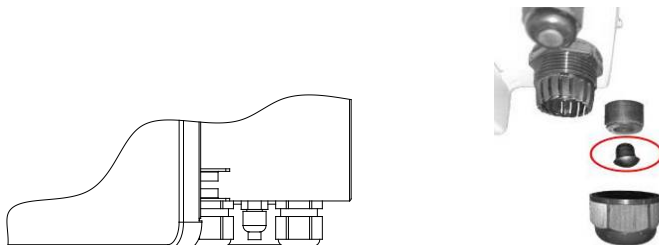
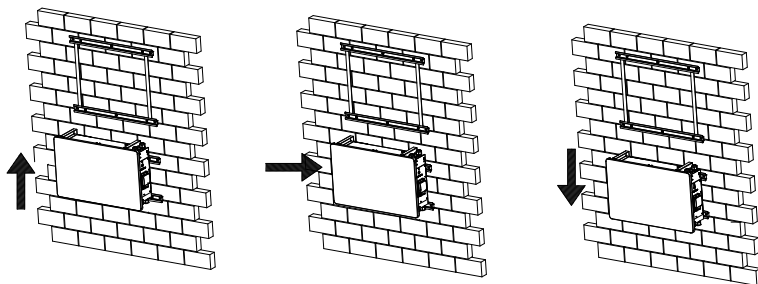

Fig. 3.13 Waterproof rings.

Step 4: If there are more than one unit of B1 connected to the AS1, please install B1 No.3 first, B1 No.2 secondly, B1 No.1 thirdly and AS1 finally (refer to Fig.3.15), from bottom to top. Please hang the AS1 & B1 to the mounting bracket with the order as mentioned above and make sure all equipment are attached to the bracket well.



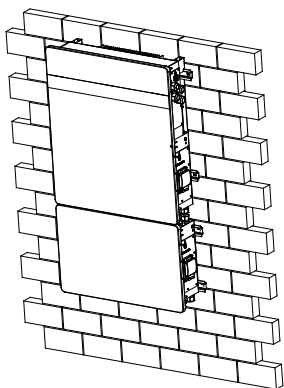

Fig. 3.14 Hang B1 & AS1 together to the mounting brackets

Chapter 4 Electrical Connections

4.1 Electrical Interface Description

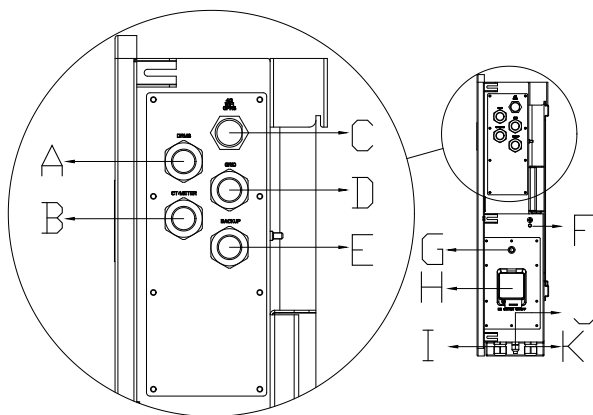

Fig. 4.1 AS1-3KS-5.1 electrical interfaces

Code	Name
A	DRMS Port
B	CT connection
C	RS232 communication
D	Grid connection
E	Backup connection
F	Ground
G	BMS switches
H	Battery switches
I	BAT+
J	BMS LINK
K	BAT-

Table 4.1 Interface description

4.2 System Wiring Schematic

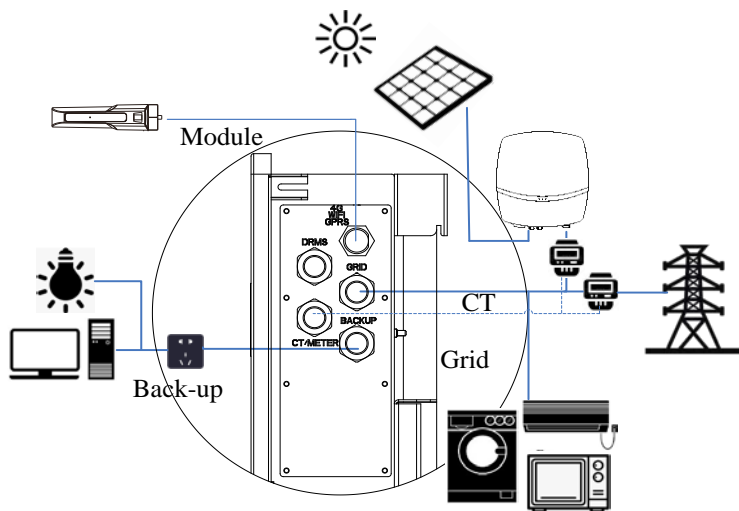

Fig. 4.2 Wiring schematic diagram

Do not connect the backup loads side with the grid or battery

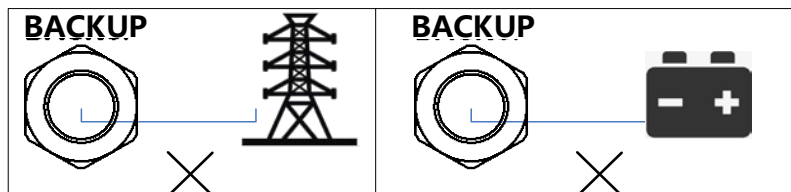

Fig. 4.3 Wrong connection example

4.3 AS1 Wiring

Notice: Please turn off the Battery Switch and DC Switch as well as external AC breaker after unpacking in any cases before and during wiring in case of electric shock.

Wiring Methods for AS1:

Step 1: Please unscrew the screws and remove the cover plates on right UPPER side of the AS1 for wiring. Please be cautious when unplug battery switch cable during dismantling.

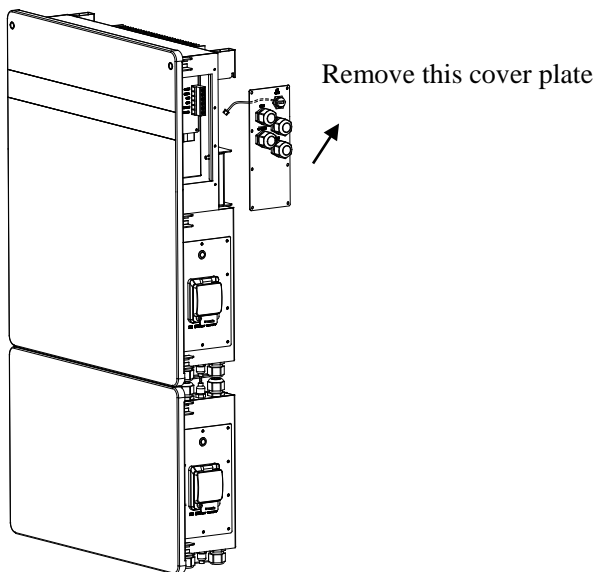

Fig. 4.3 Dismantling Covers from the AS1

Step 2: After the cover plate removed, please lead one cable (Recommend conductor core size: 2.5mm²) through the waterproof nut (GRID) and then use E6012 wire crimps to connect the wires to the terminal of GRIDL, GRIDN and GND2 properly (refer to Fig.4.4);

Step 3: Please lead another cable (Recommend conductor core size: 2.5mm²) through the waterproof nut (BACKUP) and then use E6012 wire crimps to connect the wires to the terminal of BACKUP-L, BACKUP-N and GND1 accordingly (refer to Fig. 4.4);

Step 4: When you removed the cover plate, if the 4 pins connector that connected with the 4G/WIFI/GPRS port is removed, please remember to re-plug it into the terminal of 4G/WIFI.

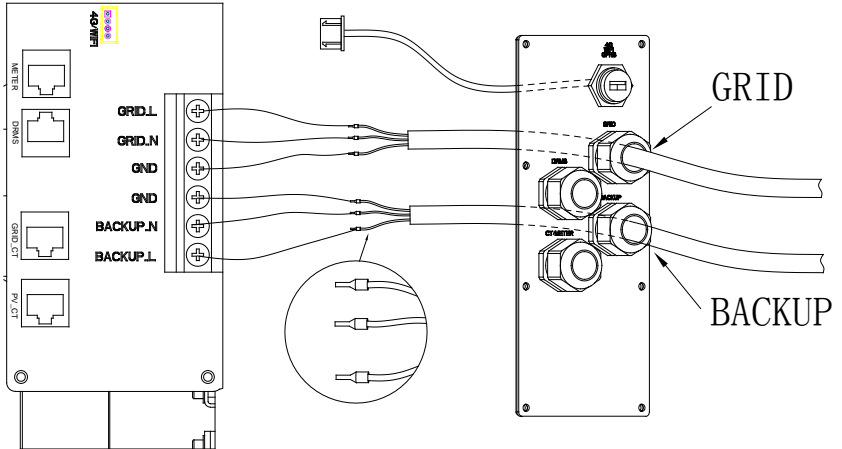

Fig.4.4 AS1 device wiring terminals

Step 5: Ground Connection

Remove the external hex head screw and lead a grounding line through OT terminal, screw it into the grounding port of AS1 enclosure (in clockwise direction) and make sure it is screwed up tightly.

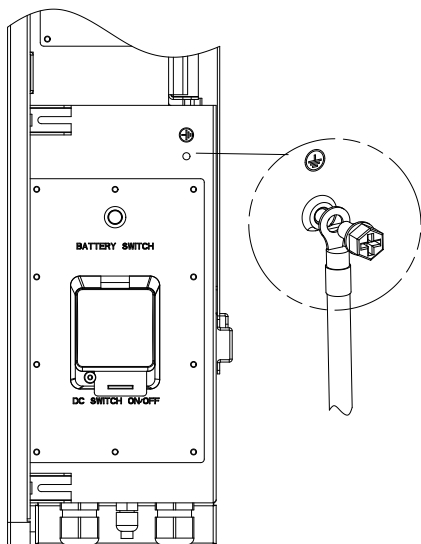

Fig. 4.5 Ground connection

4.4 B1 Wiring

Notice: If no B1 device wired to the AS1, please ignore this section).

For expanding the system capacity, the B1(s) shall be paralleled to the AS1.

Ensure DC switch is off during installation to avoid the risk of

short circuit caused by wrong operation during battery wiring.

To parallel B1 to the AS1, please follow the procedures below:

Step 1: Please remove battery cover plate of the AS1 device from the lower right area and right side of the B1 unit before wiring. (The cable connected to the Battery Switch inside the cover plate can be plugged out first if needed).

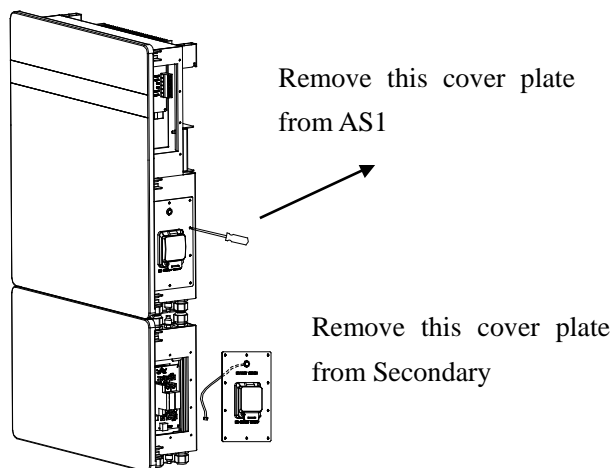

Fig. 4.6 Removing the cover plate from AS1 and B1

Step 2: Lead power lines through the waterproof nut of the AS1 and B1 respectively, make sure the lines are connected correctly (BAT+ of AS1 to BAT+ of B1, BAT- of AS1 to BAT- of B1 and LINK of AS1 to LINK of B1).

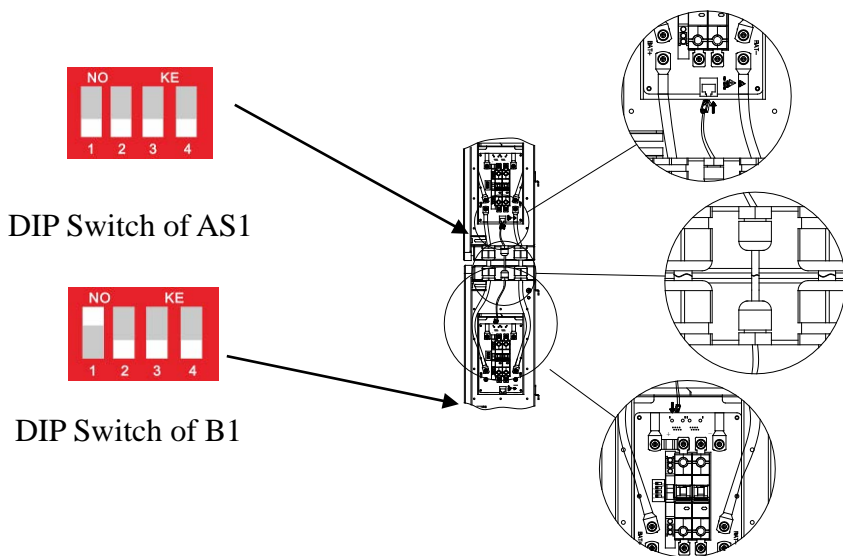

Fig. 4.7 Secondary device wiring terminal

Step 3: Lead the RJ45 communication cable (not press the RJ-45 plugs yet) from the fastening head of AS1 to the fastening head of B1 (30kgf.cm (torque) is recommended). Then press the RJ-45 plugs to the end of the RJ45 cable and connect the cable to the RJ45 terminals in the PCBA of AS1 and B1 separately so the AS1 can communicate with the B1.

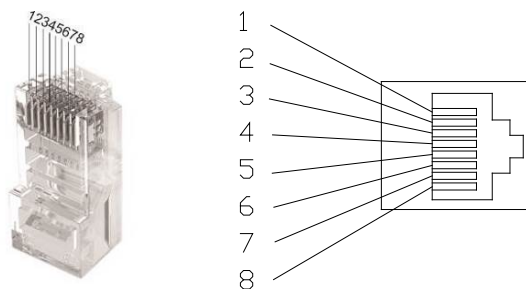

Fig. 4.8 RJ45 pins of LINK

Pin Number	Description	Effect
1	White-orange	NC
2	Orange	NC
3	White-green	NC
4	Blue	NC
5	White-blue	NC
6	Green	NC
7	White-brown	L
8	Brown	H

Table4.1 LINK pins description

DIP switch configuration can be found below:







NO.	Configuration	AS1 (DIP)	Secondary (DIP) NO.1	Secondary (DIP) NO.2	Secondary (DIP)NO.3
1	1*AS1 Only				
2	1*AS1 & 1*B1				
3	1*AS1 & 2*B1				
4	1*AS1 & 3*B1				

Table 4.2 DIP switch configuration

Step 4: Please reconnect Battery Switch cable into (PCBA-CN3) port of PCB of the AS1 and B1 before screw up the plates, then screw up the cover plates back to the AS1 and B1 respectively (14kgf.cm (torque) is recommended.

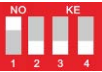
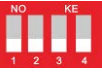
Note: The wiring methods between B1 No.3 to B1 No.2, B1 No. 2 to B1 No. 1 are the same as the wiring procedures mentioned above in

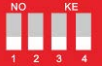
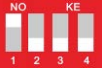
this section. Do not connect one B1 to two different AS1 devices at the same time.

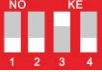
Step 5: Please use a wrench to fasten cable gland of the AS1 and B1 (30kgf.cm (torque) is recommended.) And it is recommended to apply fire resistance paint onto the cable between AS1 and B1 cable glands.

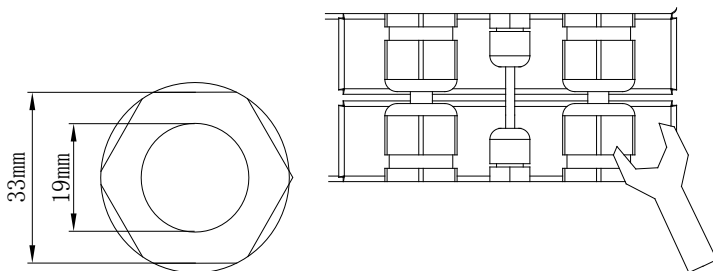

Fig. 4.9 Fastening cable gland

4.5 Communication Interface Description

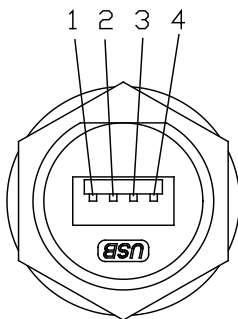

Fig. 4.10 RS232 pins

Pin number	Name
2	RS-232 TX
3	RS-232 RX
4	GND

Table 4.3 RS232 pins description

Note: The RS232 interface can be connected to the eSolar GPRS/4G/WiFi module. For operation details, please refer to the quick installation guide of each monitoring module.

4.6 Inverter Demand Response Mode

To comply with Australian and New Zealand safety requirements, the DRMs terminals should be connected. A RJ45 plug is being used as the inverter DRED connection.

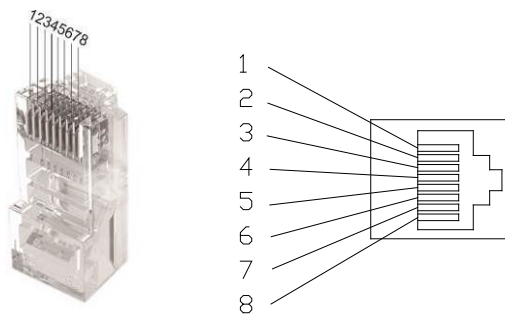

Fig. 4.11 DRMS pins

Mode	Corresponding pins	Requirement
DRM0	5 & 6	The inverter is on standby mode
DRM1	1 & 6	The inverter is not consuming power

DRM2	2 & 6	The inverter is consuming less than 50% of rated power
DRM3	3 & 6	The inverter is consuming less than 75% of rated power AND source reactive power if capable
DRM4	4 & 6	The inverter is consuming 100% of rated power (Subject to constrains from other active DRMs)
DRM5	1 & 5	The inverter is not generating power
DRM6	2 & 5	The inverter is generating less than 50% of the rated power
DRM7	3 & 5	The inverter is generating less than 75% of the rated power AND sink reactive power if capable
DRM8	4 & 5	The inverter is generating 100% of rated power (Subject to constrains from other active DRMs)

Table 4.4 DRMS requirement

4.7 CT Installation

Different solutions are offered for sampling data from PV and Grid side. The standard solution is CT solution and the optional solution is Meter solutions. Please choose to use one of the solutions to realize the sampling function.

Please do not use the CT (standard solution) and meters (optional solution) in a same system, otherwise the system will run abnormally.

4.7.1 CT (Opening-closing current transformer) solution

Two CT offered, one is PV_CT and the other one is Grid_CT.

If choose CT solution, please install CTs with instructions as below:

- 1) Remove the cover plate of the AS1.
- 2) Open the Grid_CT by pushing the buckle on its side.
- 3) Lead the Live of the Grid through the Grid_CT (refers to Fig. 4.13).
- 4) Tighten up the Grid_ CT buckles.
- 5) Lead RJ45 plug of the Grid_CT line to pass through waterproof nut (CT/METER) on the AS1 and connect the RJ45 plug to GRID_CT port on the PCBA of the AS1;
- 7) Open the PV_CT by pushing the buckle on its side.
- 8) Lead the Live of PV through the PV_CT (refers to Fig. 4.13).
- 9) Tighten up the PV_CT buckles.
- 10) Lead RJ45 plug of the PV_CT line to pass through waterproof

(CT/METER) nut on the AS1 and connect the plug to PV_CT port on the PCBA of the AS1;

Notice: Both CTs directions shall point to the load side. Please notice the CT direction.

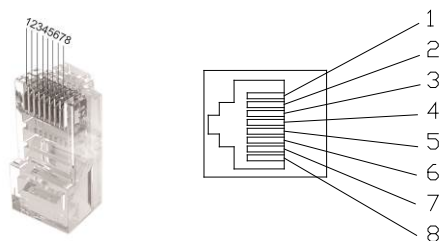

Pin	Name	Pin	Name
1	NC	5	NC
2	NC	6	NC
3	NC	7	RS485 A
4	NC	8	RS485 B

Fig. 4.12 CT/Meter pins

Table. 4.5 CT/Meter pins

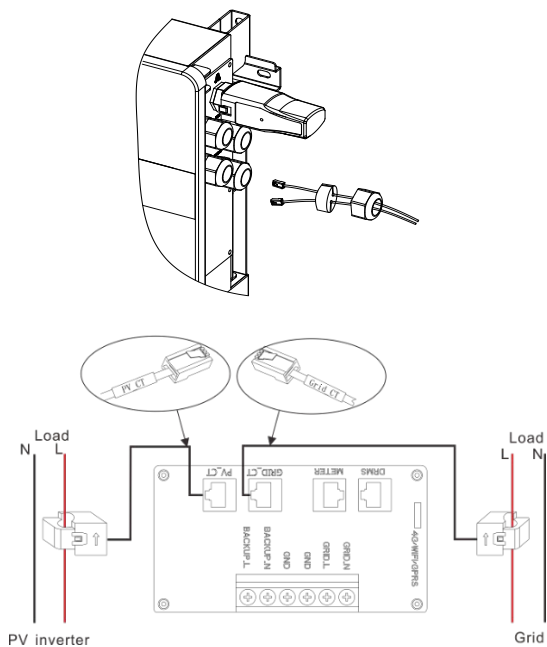

Fig. 4.13 CT installation

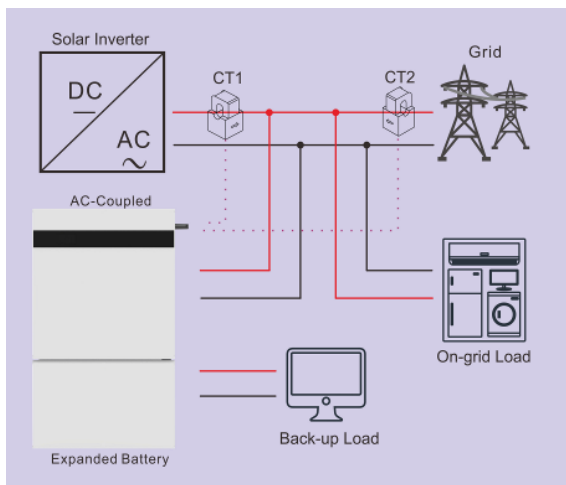

Fig. 4.14 CT connection Diagram

4.7.2 Meter Solution

There are two types of smart meters (built-in CTs) available for varied system types.

Model	Accuracy Class	Frequency	Reference Voltage	Instrument constant
DDSU666	Active Class 1	50Hz	230V	800imp/kWh
DTSU666	Active Class 1	50Hz	380V	400imp/kWh

Table 4.6 Meter Models Specification

Please choose to use single phase or three phase meters based on the Grid and PV system types. Cannot use single phase and three phase meters at a same time.

4.7.2.1 Three Phase Grid & Three Phase PV System

In a three phase grid & three phase PV system, two units of three-phase meters can be used to sample voltage and current at PV side and grid side separately.

Please install the two units of 3-phase meters with reference diagram as showed in Fig. 4.15.

After installation, please set the meter (Grid side) address into 1 and set the meter address (PV side) address into 2. (Please refer to section 4.8.2 for setting methods.)

Usually the default address of meter (Grid side) is 1.

Note: Cable color code may vary from country to country.

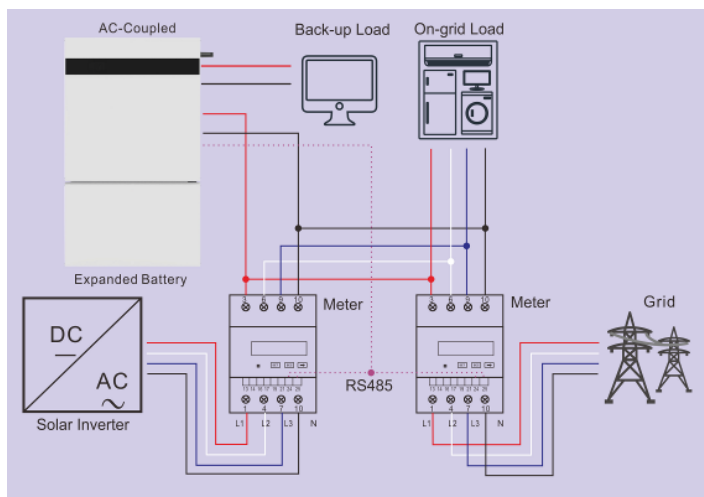

Fig. 4.15 Two three-phase meters

4.7.2.2. Single Phase Grid & Single phase PV system

In a single phase grid & single phase PV system, one unit of three-phase meter shall be used to sample voltage and current.

Phase C of the meter is used to sample voltage and current value of the PV side, while Phase A of the meter is used to sample voltage and current value of the grid side.

Please install the 3-phase meters with reference diagram as showed in Fig. 4.16.

The default address for the meter is 1 in this case.

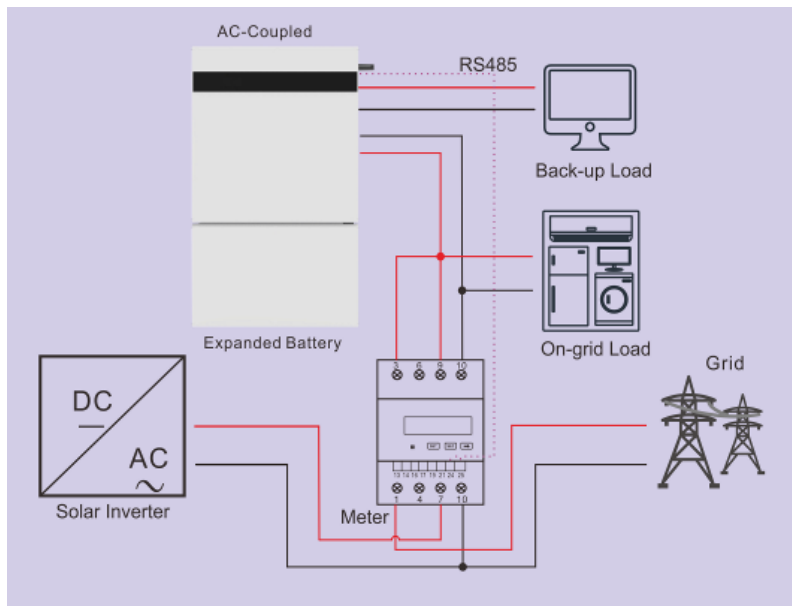

Fig.4.16 Wiring diagram for one unit of three phase meter

4.7.2.3. Single Phase Grid & Single Phase PV System

In a single phase grid & single phase inverter system, two units of single -phase meters can be used to sample voltage and current at PV side and grid side.

Please install the 1-phase meters with reference diagram as showed in Fig. 4.17.

Please set the meter address (Grid side) into 1 and set the meter address (PV side) into 2.

Please refers to section 4.8.1 for meters setting methods.

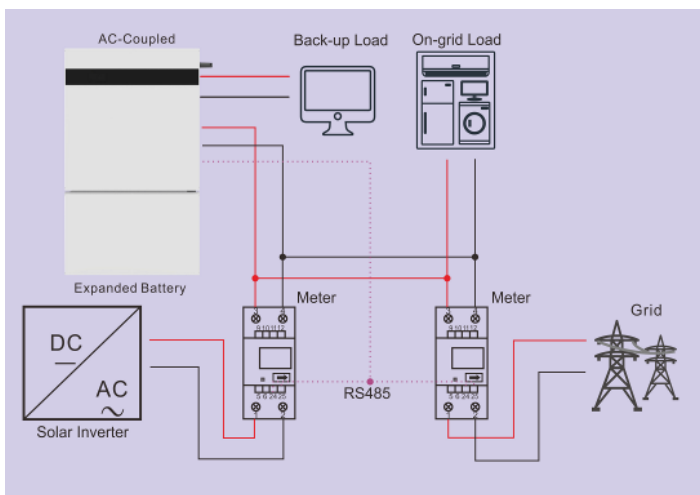

Fig. 4.17 Wiring diagram to two units of single phase smart meters

4.8 Meter Address Setting

Notice: If CT solution is adopted only without using any meters,

please ignore this section.

4.8.1 Setting Methods for Single Phase Meter

The setting methods for single-phase meter is as follows:

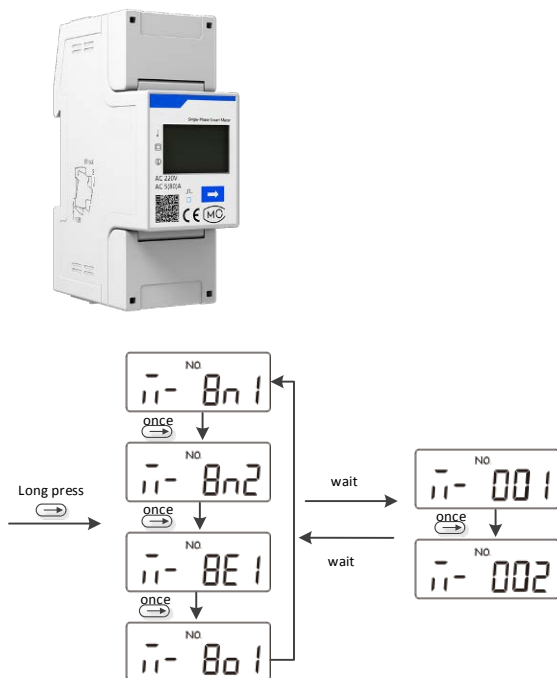

Fig. 4. 18 Procedure of single phase meter address setting

① Power on the meter to the display interface and long press



button to enter meter switching interface, select



and wait for 2s to enter meter address page automatically.

② After entering the address page, please press  to set meter address according to the system type into 1 or 2.

③ After the address is set, the interface will jump to the initial display interface and no further operation is required to start the meter.

4.8.2 Setting Methods for Three phase meter

The setting methods for three-phase meter is as follows.

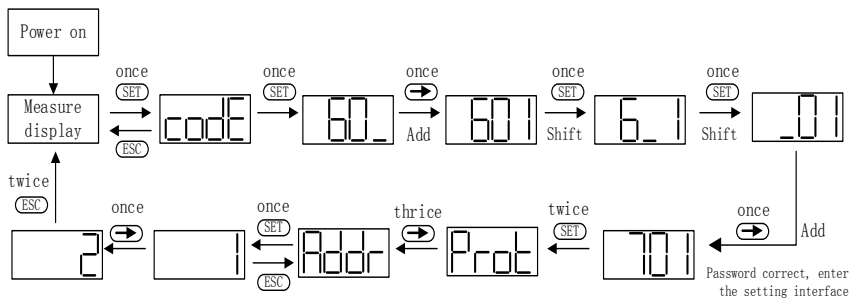

Fig. 4.19 Procedure of three phase meter address setting

- ① Power on the meter and enter the “Measure display” interface, then press **SET** button twice for entering password 701.
- ② Press **→** button once to adjust the value of the first digit, one increment per button pressing.
- ③ Pressing **SET** button once to shift to the second digit, same methods to adjust value as for the first digit, then adjust the third digit in a same way, set the default password into 701.
- ④ When the password entered correctly, press **SET** twice to enter the Port interface then press **→** for three times to enter address page, and press **SET** button once to start to set meter address.
- ⑤ Pressing **→** button to adjust the value of address, one

increment per button pressing

- ⑥ After the address set successfully, press **ESC** button twice to exit to Measure display interface to get the meter work.

	Button	Description
	SET	Confirmation or cursor shift (when input digits)
	ESC	Exit
	→	Add

Table 4.3 Button description of three phase meter

4.7 External AC Circuit Breaker and Residual Current Device

Please install a circuit breaker to ensure the inverter is able to disconnect from grid safely. The inverter is integrated with a RCMU, however, an external RCD is needed to protect the system from tripping, either type A or type B RCD are compatible with the inverter.

The integrated leakage current detector of inverter is able to detect the real time external current leakage. When a leakage current detected exceeds the limitation, the inverter will be disconnected from grid quickly, if an external residual current device is connected, the action current should be 30mA or higher.

Chapter 5 Debugging Instructions

5.1 Human-computer Interface Introduction

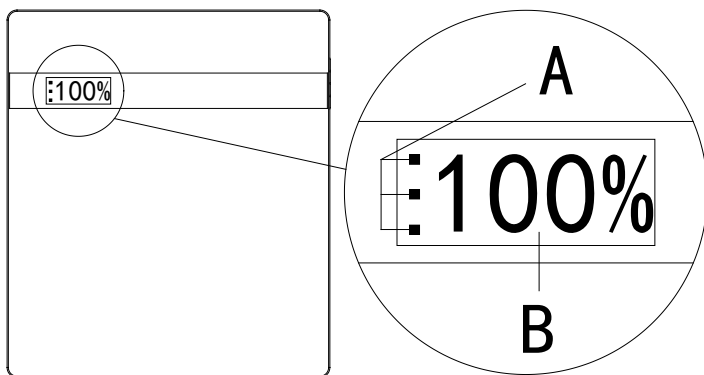

Fig. 5.1 Human-computer interface

		LED lamps state	Description
A	Green/Red LED lamp	Green lamp flicker from bottom to top	Battery discharging
		Green lamp flicker from top to bottom	Battery charging
		Red lamp flicker:1 s/time	Standby
		Green lamp and red lamp flicker in alternative	Procedures are being upgrade
		Red lamp Always light on	Faults in device
B	Residual battery capacity percentage (SOC)	Total remained battery capacity of the system	

Table 5.1 Human-computer interface description

5.2 Start Up the Inverter

If only AS1 is installed, the system shall be turned ON in the correct sequence as follows:

- 1) Turn ON the DC switch at the right side of the AS1;
- 2) Turn on the battery switch at the right side of the AS1 until it lights in blue.
- 3) Wait for 30s and observe the LED indicators and LCD on the front of AS1 to check the running status of the system. (Please refer to Table 5.1)

If there is any B1 connected to the AS1, the system shall be turned ON in the correct sequence as follows:

- 1) Turn ON the DC switch at the right side of the B1 No.3> B1 No.2>B1 No.1> AS1;
- 2) Turn on the battery switch at the right side of the B1 No.3> B1 No.2>B1 No.1> AS1;
- 3) Wait for 30s and observe the LCD and LED indicators on the front of AS1 to check the running status of the.
- 4) If the system is running normal, please do commission configuration. If the system is not work normally, please re-check your wiring and setting until the system runs normal.

Notice: If the AS1 is connected with B1 device(s), the start-up procedure for the system should be B1 No. 3>> B1 No. 2>> B1 No.1>> AS1 (refer to figure 3.12).

5.4 System Commissioning

Please refer to eSolar 4G/Wi-Fi Module Quick Installation Guide for details.

5.4.1 Install Commission Tool

Installers shall install the commission App (eSolar SET) to the smart phone for commission configuration.

>>For iOS system, please search “eSolar SET” in App Store to download and install this APP.

>>For Android system, please search “eSolar SET” in Google play to

download and install this APP.

5.4.2 Commission Configuration

Step 1: Login to the commission App with user name and account

Step 2: Set the grid compliance, time zone as per instructions showed on the App.

Step 3: Select the system operation Mode (refer to Appendix I)

Step 4: Installer shall create account for End user (refer to 4G/Wi-Fi Module user manual)

Step 5: Checking the system operation status

Notice: Default password for commission is 123456

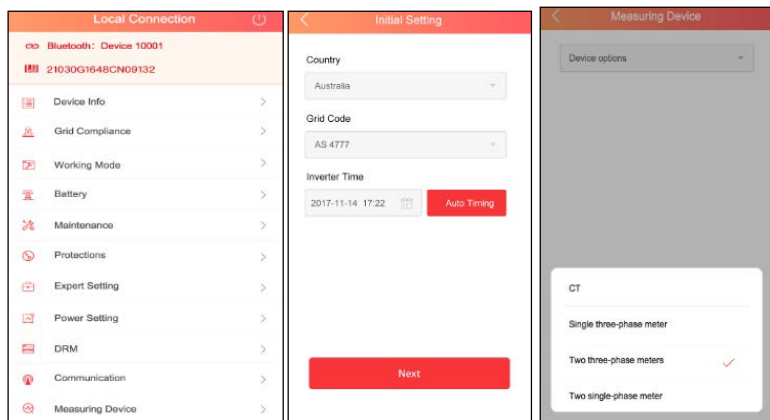

Figure 5.2 APP Setting

5.5 Shut Down the Inverter

Notice: If the AS1 is connected with B1(s), the procedure for turning off the system will be B1 No.3>> B1 No.2>> B1 No.1>> AS1 (refer to Fig. 3.12)

System shall be turned OFF in the correct sequence as follows:

- 1) Turn OFF the DC switch on the right side of the AS1/B1
- 2) Press (approx. 5 seconds) the battery switch on the right side of the AS1/ B1 until the battery switch is off (not light in blue).
- 3) Disconnect the external grid AC switch

Chapter 6 Fault Codes and Common Troubleshooting

	Explanation	Fault type
01	Communication loss of the main and subordinate machine Master	Error
02	High temperature Master	Error
03	Low temperature Master	Error
04	DCI Err Master	Error
05	Synchronizing pulse fault Master	Error
06	Relay fault Master	Error
07	Storage fault Master	Error
08	Battery input short circuit Master	Error
09	Battery overvoltage Master	Error
10	Battery open circuit Master	Error
11	DC side hardware overcurrent	Error

	Master	
12	Battery discharging fault Master	Error
13	Battery controller overcurrent Master	Error
14	Bus soft-start timeout Master	Error
15	Bus voltage high Master	Error
16	Bus voltage low Master	Error
17	Bus voltage high of hardware Master	Error
18	Inverter overcurrent Master	Error
19	Inverter hardware overcurrent Master	Error
20	Inverter short circuit fault Master	Error
21	Output overload Master	Error
25	Voltage of grid high warning Master	Alarm
26	Voltage of grid low warning Master	Alarm
27	Frequency of grid high warning Master	Alarm
28	Frequency of grid low warning Master	Alarm
29	Grid loss warning Master	Alarm

30	Grid average overvoltage within 10 mins Master	Alarm
31	Overload alarm Master	Alarm
33	Fan Err Slave	Error
34	Output terminal abnormal Slave	Error
35	Inverter voltage wave form fault Slave	Error
49	Grid voltage consistent alarm Slave	Alarm
50	Grid frequency consistent alarm Slave	Alarm
51	GND Loss Warn	Alarm
52	LN Wrong Warn	Alarm
53	CAN communication loss Slave	Alarm
54	Low battery SOC alarm Master	Alarm
55	Voltage of battery high alarm Master	Alarm
56	Voltage of battery low alarm Master	Alarm

57	Voltage of grid high warning Slave	Alarm
58	Voltage of grid low warning Slave	Alarm
59	Grid over frequency alarm Slave	Alarm
60	Grid under-frequency alarm Slave	Alarm
61	Grid loss alarm warning Slave	Alarm
65	Communication loss of the main and subordinate machine Slave	Error
66	Storage fault Slave	Error
67	RTC fault Slave	Error
68	BMS equipment fault Slave	Error
81	Unit cell over-voltage alarm Slave	Alarm
82	Unit cell under-voltage alarm Slave	Alarm
83	Over charging current alarm Slave	Alarm
85	Over discharging current alarm Slave	Alarm
86	Over discharging temperature alarm Slave	Alarm

87	Over charging temperature alarm Slave	Alarm
88	Battery low voltage alarm Slave	Alarm
89	BMS communication loss alarm Slave	Alarm
91	Ammeter communication loss alarm Slave	Alarm
92	DRM0 alarm Slave	Alarm

Chapter 7 Inverter & battery maintenance

7.1 Transportation

Lithium batteries are dangerous goods. Passed the test of UN38.3, this product meets the transportation requirements for dangerous goods for lithium batteries. After the installation of the battery on site, the original packaging (contains the lithium battery identification) should be kept. When the battery needs to be returned to the factory for repair, please pack the battery with the original packaging to reduce unnecessary trouble.

7.2 Storage

After purchasing the battery, please store it with following instructions:

- 1) Please store it in a dry and ventilated environment, keep it away from heat sources;
- 2) Please keep it in an environment with storage temperature as $-20^{\circ}\text{C} \sim 50^{\circ}\text{C}$, humidity $<85\% \text{ RH}$;
- 3) For long-term storage (>3 months), please put it in an environment with a temperature of 18°C to 28°C and a humidity of $< 85\% \text{ RH}$;

4) The battery should be stored in accordance with the storage requirements mentioned above, and the battery should be installed within 6 months since delivered from the factory and used with compatible inverters;

Notice

·The battery remains 40% power when it is sent from the factory.

·The longer the battery is stored, the DOD value is getting bigger.

When the battery remaining voltage fails to reach the startup voltage requirement, the battery may be damaged.

·Judgment condition: Close the battery breaker switch and press the BMS switch. At this time, if the LED light is flashing, it is running normal. If the LED light is off, the battery is in faulty.

The battery cannot be disposed of as household refuse. When the service life of the battery reaches to the limit, it is not required to return it to the dealer or SAJ, but it must be recycled to the special waste lithium battery recycling station in the area

7.3 Cleanliness

Clean the enclosure lid, LCD and LED indicator of the inverter with moistened cloth with clear water only. Do not use any cleaning

agents as it may damage the components.

Appendix I: Brief Introduction about the

system operation modes:

Self-consumption Mode

The power generated by the energy storage system will mainly be used to support the load, and surplus power will be adopted for battery charging and once the battery is full, the more surplus energy will be fed into the grid. It can effectively improve PV generation self-use rate.

Users can not only save their electricity bill but also can get more money by selling power to the grid.

Time-of-use Mode

Time-of-use mode is set based on the time-of-use tariff system. In the electricity market where the time-of-use electricity price is implemented, users can choose to charge the energy storage system when the electricity price is low and discharge when the electricity price is high, which can not only reduce the overall electricity consumption cost through low storage and high discharge, but also

do not need to change the electricity consumption habits of users. Revenue from TOU price management is mainly obtained through price difference and adjustment of electricity utilization plan.

Operating with this mode, users can arrange the electricity utilization plan according to their actual situation, and transfer the electricity demand from the period with higher electricity price to the period with lower electricity price to achieve the purpose of reducing the overall electricity price level.

Back-up Mode

Energy storage is used to improve the power supply reliability of microgrid, which means that when a power failure occurs, the energy storage can supply the stored energy to the end user, thus avoiding power interruption in the fault repair process to ensure the power supply reliability.

In Back-up mode, the battery system will supply power to the loads first and to store surplus energy in the battery as standby capacity for ensuring stable operation of the system in case of grid blackout. The spare capacity can be called at any time to satisfy the back-up load.

Appendix II: Setting Reactive Power Control

Setup Fixed Power Factor mode

The characteristic power factor curve for $\cos\phi$ (P) (Power response) mode varies

the displacement power factor of the output of the inverter in response to changes

in the output power of the inverter.

The response curve required for the $\cos\phi$ (P) defined within displacement power

factor of 0.8 leading to 0.8 lagging.

Setup V-Watt and Volt-Var mode

This inverter complies with IEC 62109-2 clause 6.3 for power quality response

modes. The inverter satisfies grid connection rules requirements for volt-watt and

volt-var Settings. e.g.: AS4777 series setting as below :

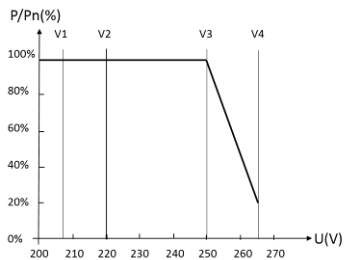

Curve for a Volt-Watt response mode (AS4777 Series)

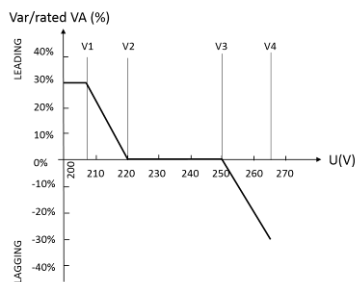

Curve for a Volt-Var control mode (AS4777 Series)

Chapter 8 Contact Us

Guangzhou Sanjing Electric Co., Ltd.

Headquarter: SAJ Innovation Park, No.9, Lizhishan Road, Science City, Guangzhou High-tech Zone, Guangdong, P.R.China.

Jiangxi Factory: Building D10, D11, Ganzhou International Port Electronic Info Industrial Park, Longling Town, Nankang District, Cangzhou City, Jiangxi Province

Website: <http://www.saj-electric.com/>

Technical support & service hotline: 400-960-0112

Fax: 020-66608589

Email: service@saj-electric.com

International sales

Tel.: 86-20-66608618/66608619/66600082/66600086

Fax: 020-66608589

Email: info@saj-electric.com

Domestic sales

Tel.: 020-66600058/66600082

Fax: 020-66608589

Warranty Card

The installer should fill in the second form while installing the inverter. For warranty claim, please complete the below forms and send this page to SAJ, attached with the Customer's invoice.

For customer to fill in

Name:		
City:	Country:	Zip:
Tel:	Fax:	E-mail:

Information on device



Device type:	Serial No.(S/N):
Invoice No:	Commissioning date:
Fault time:	
Error message (Display reading):	
Brief fault description & photo:	
Signature: Date:	

For installer to fill in



Modules used:		
Modules per string:	No. of string:	
Installation company:	Contractor license number:	
Company:		
City:	Country:	Zip:
Tel:	Fax:	E-mail:
Signature: Date:		





Guangzhou Sanjing Electric CO., LTD.

ADD: SAJ Innovation Park, No.9, Lizhishan Road, Science City,
Guangzhou High-tech Zone, Guangdong, P.R.China (Zip: 510663)

Tel: +86 20 6660 8588 Fax: +86 20 6660 8589

Web: <http://www.saj-electric.com>

Edition No: V3.0